

## Invision MX200 Ergonomic Gas Assisted Monitor Arm

### Instruction Manual

VESA Compliance 75x75mm & 100x100mm  
Recommended Screen Sizes 19" - 32"  
Load Capacity 2 - 9kg (4.4 - 19.8lbs)

### Need Help or Advice?

Contact our dedicated experts!  
help@InvisionTechnology.co.uk

#### Parts List:

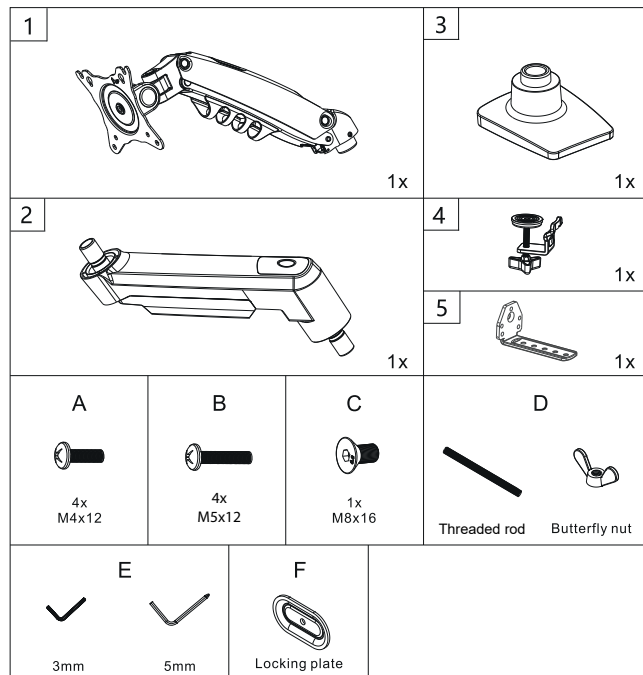

#### Tools List:

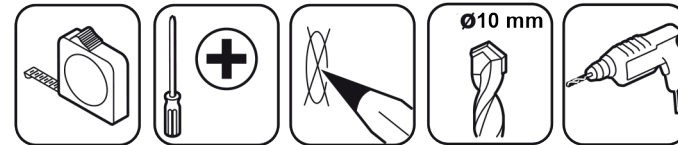

#### Important:

1. Check the box contains all the items in the Parts List.
2. Check the screens VESA mounting measurements and monitor weight.
3. Please read the instructions fully and plan how to mount your monitor.
4. You may need additional tools: A drill will only be needed if you are bolting it through a desk and a screwdriver is used to secure the monitor to monitor arm.

**Invision Technology Ltd**  
3rd Floor, Falcon Mill,  
Handel St, Bolton,  
BL1 8BL  
United Kingdom

**Authorised EU Representative**  
**24hour Solutions B.V.**  
Van Nelleweg 1  
3044 BC Rotterdam  
The Netherlands

#### UNBOXING - PLEASE NOTE: NOT FAULTY OR BROKEN

This product is packed with the faceplate at a 45° angle to fit smaller packaging and reduce environmental waste. Please rotate the faceplate 45° clockwise before mounting your monitor.

**PLEASE NOTE:** Faceplate rotation has high resistance by design and may need a little force to move. This is normal and ensures that your screen will be held steady for many years to come without any unwanted movement.

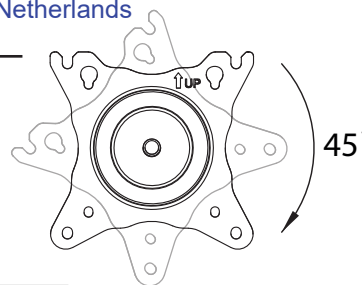

#### WARNING!

Severe personal injury and property damage can result from improper installation or assembly. Please read the following warning carefully before beginning.

- If you do not understand the instructions or have any concerns or questions, please contact us or a competent installer.
- Do not install or assemble if the product or hardware is damaged or missing. If you require replacement parts, please contact us at Invision for assistance.
- This product fits most VESA compliant 19"-32" LCD/LED monitors to a maximum weight of 9kg (19.8lbs).
- For safe installation, the desk you are mounting it to must support minimum 3 times the weight of the total load (the mount, plus the monitor and all accessories weight).
- Do not use this product for other than the original design purpose.
- This product contains moving parts, please use with caution.
- When installing monitor take care not to damage electrical wiring or power source.
- Important - mains and data cables must be free from twisting and/or shearing.
- The manufacturer disclaims any liability for the modifications, improper installation or installation over the specified weight range. The manufacturer will not be liable for any damages arising from the use of, or inability to use the product.
- This product is designed for indoor use only, use of this product outdoors could lead to product failure and severe personal injury.
- This product contains a high pressure gas piston This mechanism is not user serviceable and any interference could result in injury or damage. Please dispose of with caution.
- In order to ensure the performance of the gas piston it is recommended to fully extend the arm several times per month.

### Lets Get Started!

If you require assistance please contact us at: help@InvisionTechnology.co.uk

Letters and numbers in ( ) are referred to in the Parts List

#### Option 1 - Clamp Installation

1. Slot the Clamp Assembly (5) holes onto the alignment pegs of the Base (3). See Diagram A
2. Insert the M8x16 Screw (C) into the central hole of the Clamp Assembly (5). See Diagram B
3. Secure the M8x16 Screw (C) in place using the 5mm Allen Key (E). See Diagram C

Diagram 'A'

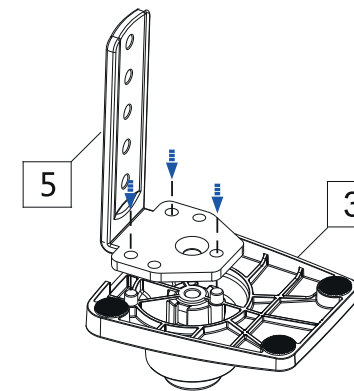

Diagram 'B'

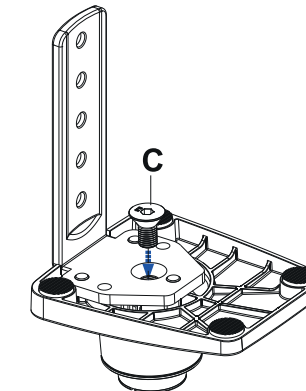
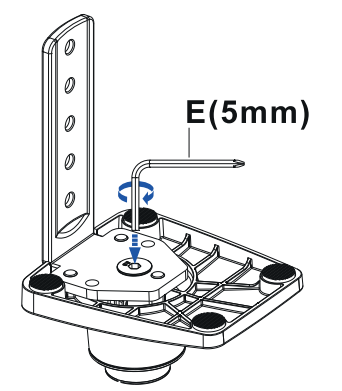

Diagram 'C'



4. Take the clamp section (4) and wind the knob out fully to its lowest position - see diagram 'D'.
5. Sit the base of the monitor arm on the desk so the clamp plate is hanging over the edge - see diagram 'E'.
6. Take the clamp section and align the hole to slide over base of clamp plate. Move the clamp section up to the highest notch possible and then straighten the clamp section so it locks in place on that notch - see diagram 'F'.
7. Wind knob and tighten to the desk making sure the clamp plate and monitor arm base is pushed up to the edge of the desk.

**Please note:** If you are mounting heavy screens on this monitor arm please evaluate the desktop/work surface you are mounting it to. (Example: Manufactured wooden surfaces like chipboard or MDF are compressed high density boards and are less likely to cause marks or indentations. Natural wooden surfaces are softer (not compressed) so you may consider adding protection.

Diagram 'D'

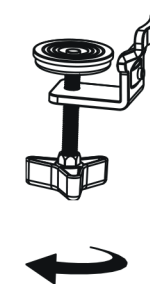

Diagram 'E'

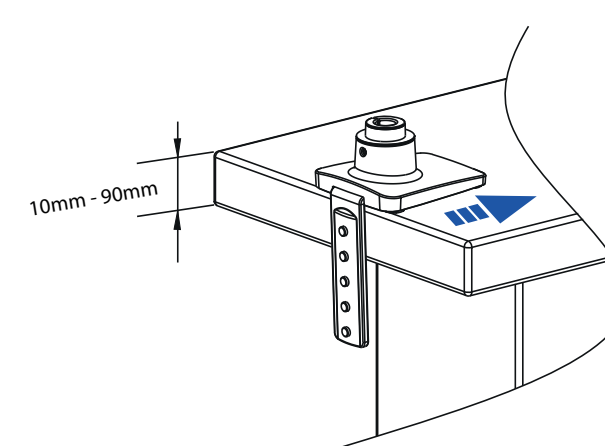
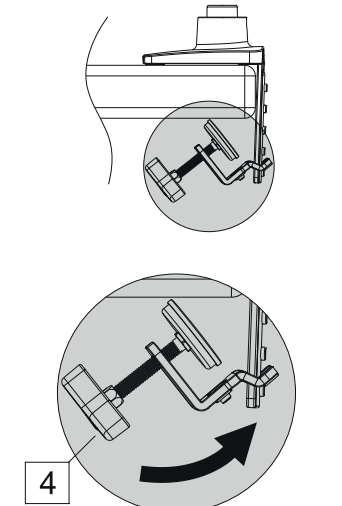

Diagram 'F'



## Option 2 - Through the Desk Installation

1. Locate and position where you want the monitor arm base to sit on your desktop/work surface. 40mm minimum is needed from the rear of the desk so the monitor arm base makes full contact with the desktop/work surface - see Diagram 'G'.

2. Measure and mark out with a pencil where you want the hole and drill the hole using a 10mm drill bit.

**Please note: If you are mounting heavy screens on this monitor arm please evaluate what desktop/work surface you are mounting it to. (Example: Manufactured wooden surfaces like chipboard or MDF are compressed high density boards and are less likely to cause marks or indentations. Natural wooden surfaces are softer (not compressed) so you may consider adding protection.**

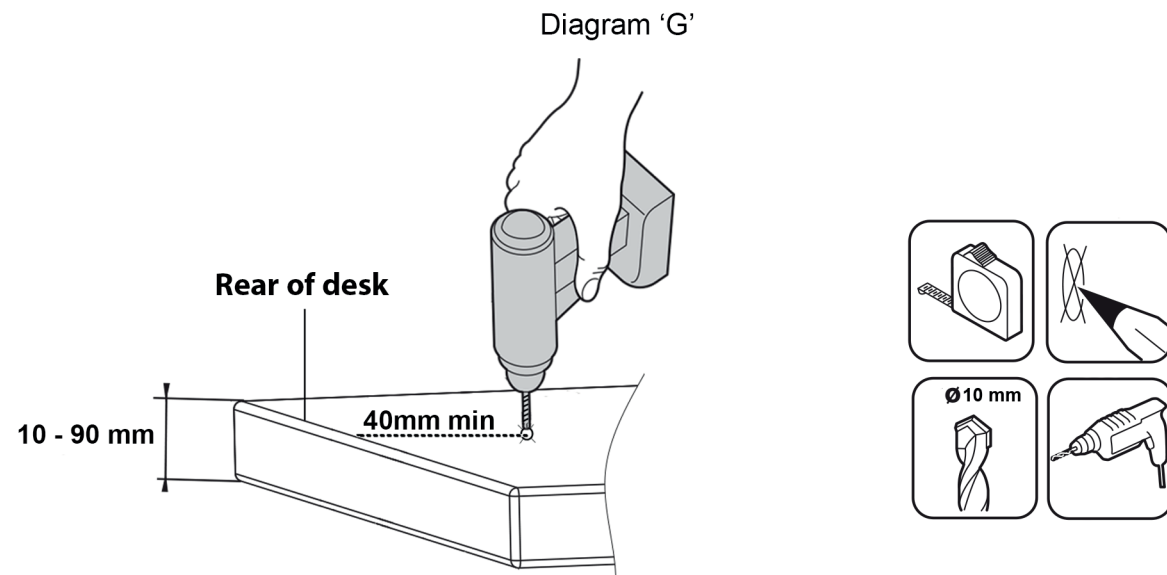

3. Fix the threaded rod (D) to monitor arm base with 4x full turns - see Diagram 'H'.

4. Pass the threaded rod through the hole made in the previous step and add clamp plate (F) and butterfly nut (D) and tighten - see Diagram 'I'.

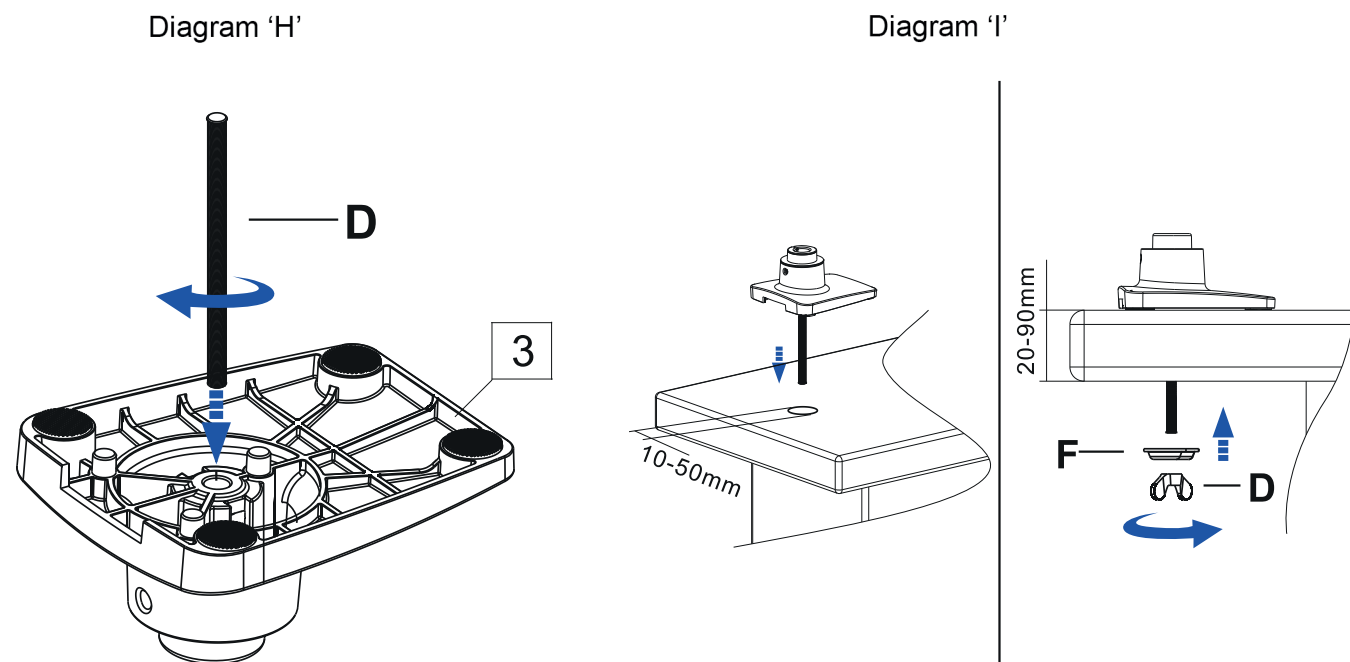

**NOTICE: CLAMP ASSEMBLY (5) IS NOT REQUIRED FOR 'THROUGH THE DESK' INSTALLATION**

## 2 - Monitor Arm Assembly

1. Take the lower arm (2) and slot the male connector into the female connection on the monitor base (3) making sure it is fully inserted (please ensure you have this the correct way up) - see Diagram 'J'. Ensure the black plastic sleeves remain in place.

Use the 3mm Allen key (E) and tighten the grub screw to lock the lower arm in place. Do not over tighten as this will hinder the rotation ability of the arm.

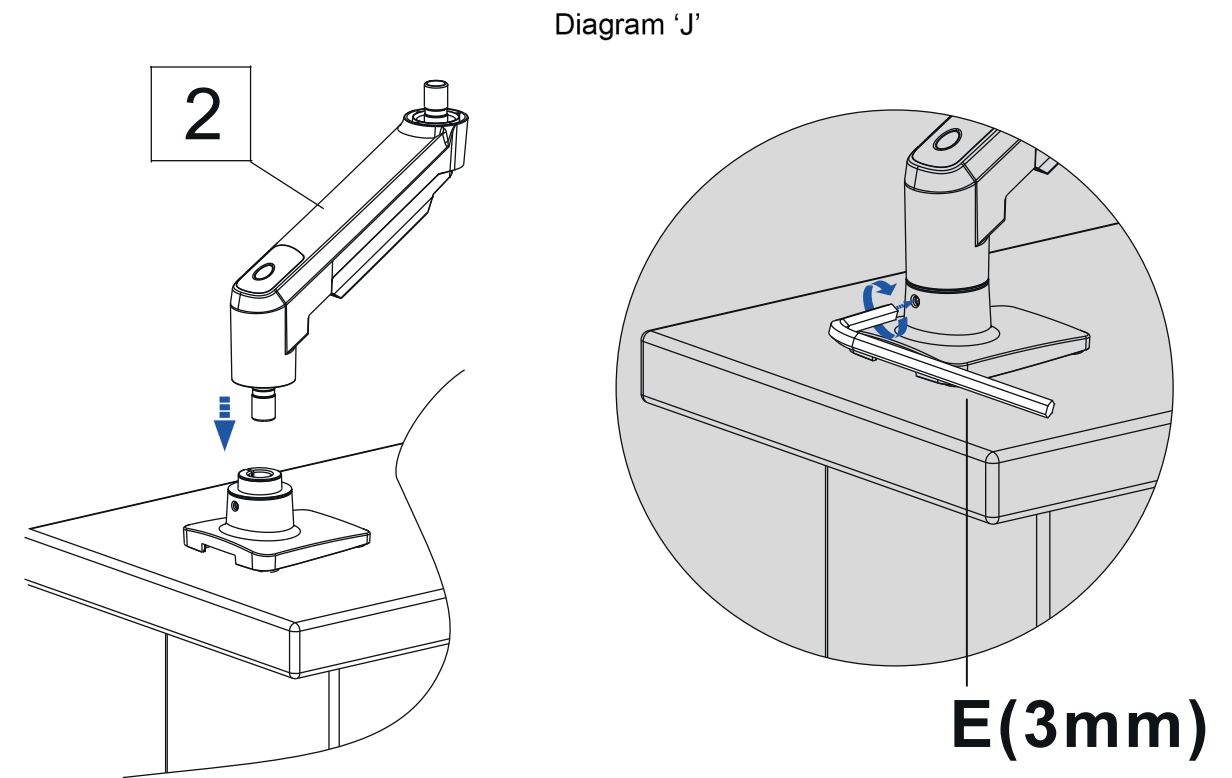

2. Take the upper arm (1) and slot the female connector onto the male connection on the lower monitor arm making sure it is fully inserted - see diagram 'K'. Use the 3mm Allen key (E) and tighten the grub screw to lock the upper arm in place.

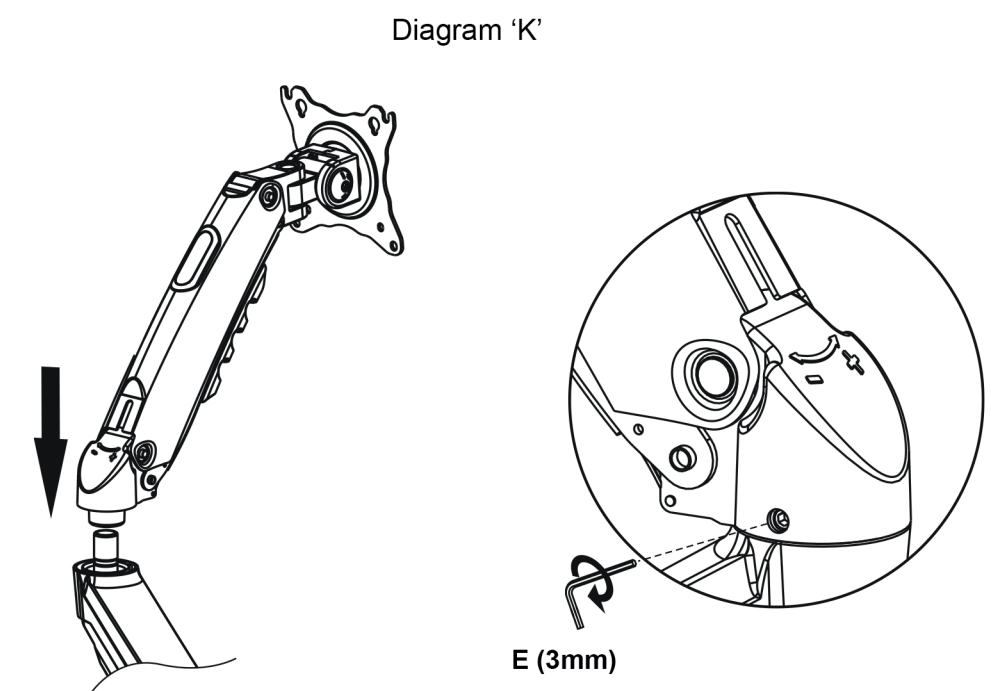

### 3 - Adding Cables to the Monitor Arms Cable Management

**Make sure there is enough slack on your cables so the product can function without pulling or stretching them.**

1. Add cables to the upper arm by pulling the cable management clip back slightly and slide the cables into the gap created - see diagram 'L'.
2. Add cables to the lower arm by sliding the cables into the gap in the cable management. Then push the cables into the channels to secure them - see diagram 'M'.
3. Once cables have been added make sure there is enough slack so the monitor arm can move around freely, this will prevent cables from snagging or stretching - see diagram 'N'.

Diagram 'L'

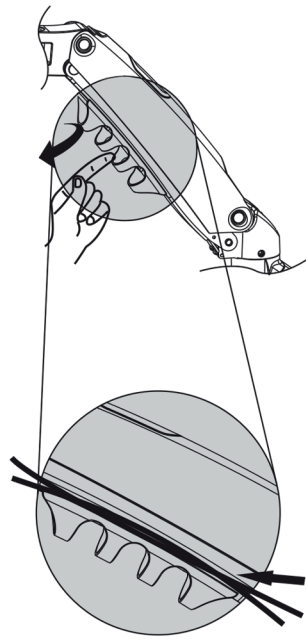

Diagram 'M'

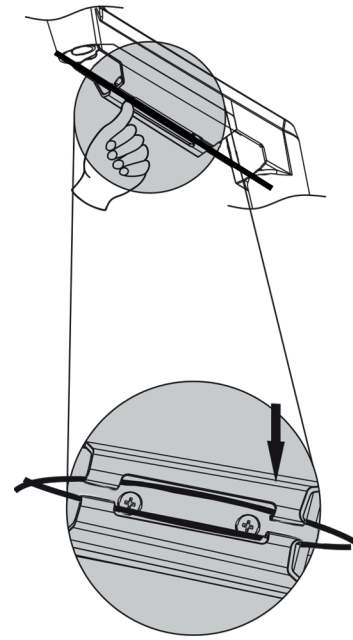
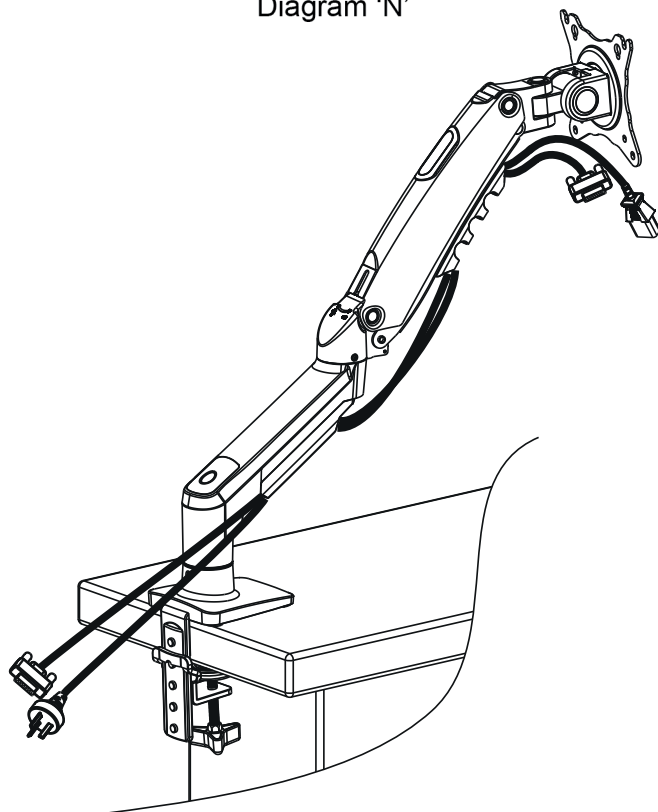

Diagram 'N'



### 4 - Mounting the Monitor

1. Check the monitor's VESA by measuring the distance between the mounting holes on the back of the screen - this is where either screws A or B will fit - see Diagram 'O'.
2. Screw 2 screws into the top two holes on the back of the monitor using screws (A) or (B) and tighten in 3 turns leaving room between the screw head and rear of screen for hanging the monitor - see Diagram 'P'.

**Please note: Some recessed monitors may require a combination of bolts, washers and spacers.**

3. Carefully lift monitor and hang onto the face plate.
4. Fit the bottom 2 screws into the face plate and tighten all the screws see Diagram 'Q'.

**Please note: Set the torque of arm if screen moves down too easily (see Step 6).**

Diagram 'O'

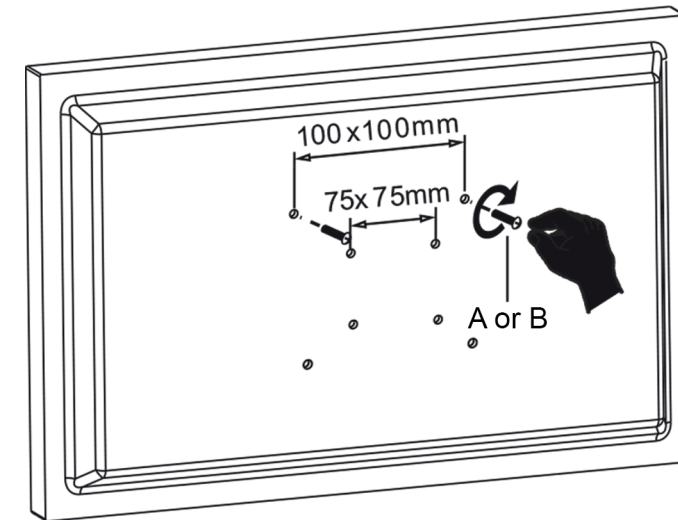

Diagram 'P'

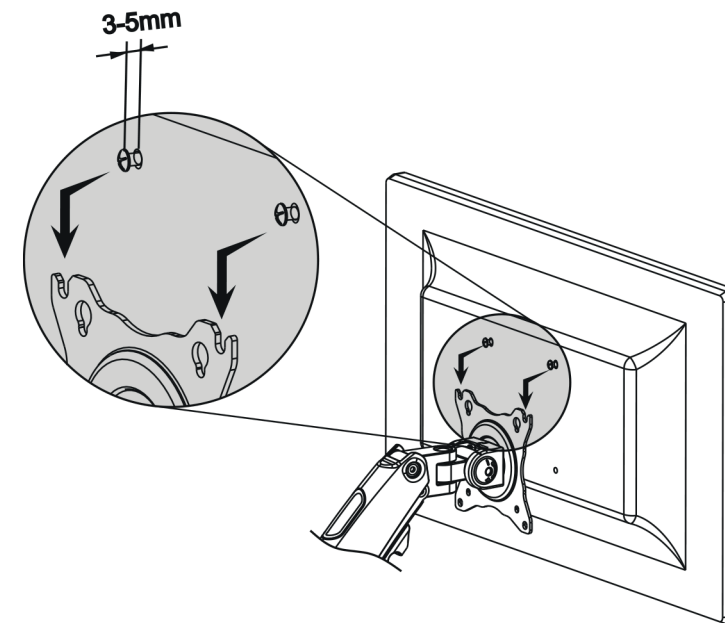
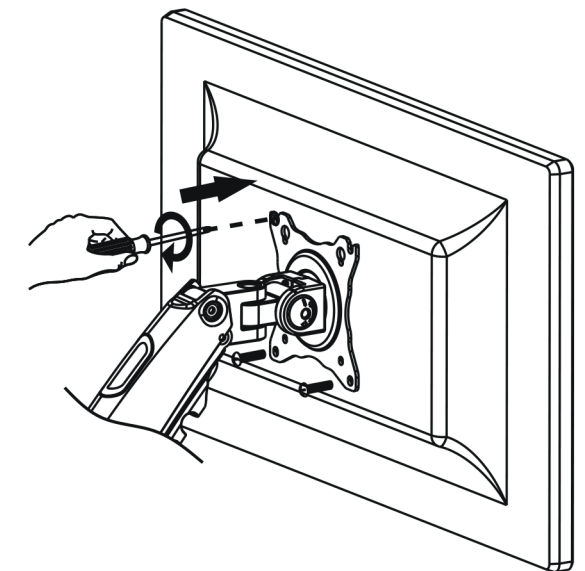

Diagram 'Q'



## 5 - Using Your Invision MX200 Ergonomic Monitor Arm

### Setting the tension of the monitor arm to balance the weight of the monitor

Once fitted the screen may raise or lower depending on the monitor's weight. From minimum tension to maximum tension there are 19 full rotations. When adjusting make one full turn of the Allen key and check by depressing the upper arm to see if the monitor is balanced evenly.

1. If the screen moves upwards of its own accord then adjust the tension using the 5mm Allen key (E) and wind the Allen head screw in the minus (-) direction (clockwise).
2. If the screen moves downwards of its own accord then adjust the tension using the 5mm Allen key (E) and wind the Allen head screw in the plus (+) direction (anti-clockwise).

Continue to adjust until the monitor weight feels equal to the tension of the monitor arm. It should hold in place when positioning the monitor and not raise or lower of its own accord.

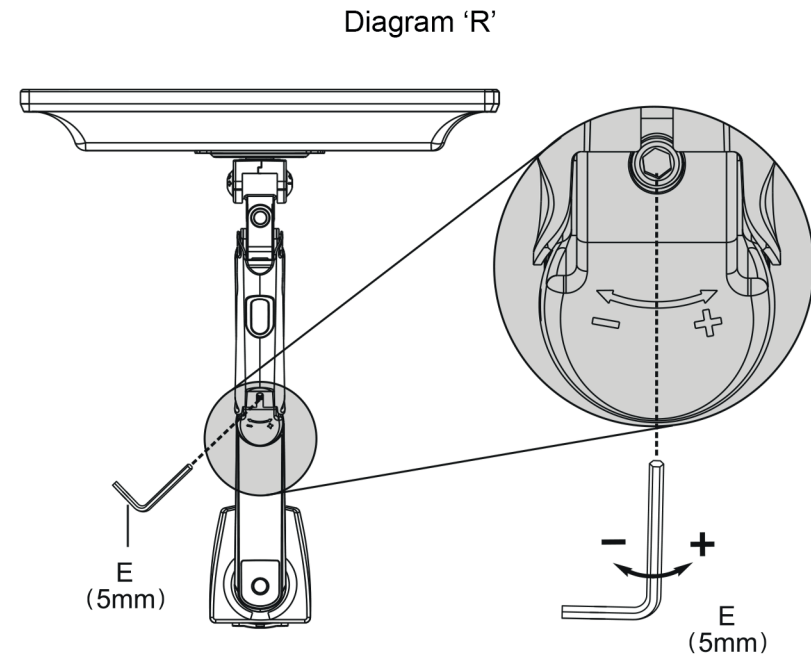

### 6 - Adjusting the Tilt Angle

The tilt can be set to your desired viewing angle by simply moving the screen backwards and forwards by hand. If the screen moves freely you need to adjust the tilt tension mechanism.

1. To tighten the tilt adjustment use the 5mm Allen key (E) and turn the Allen key head adjustment screw in the plus direction - see diagram 'S'.

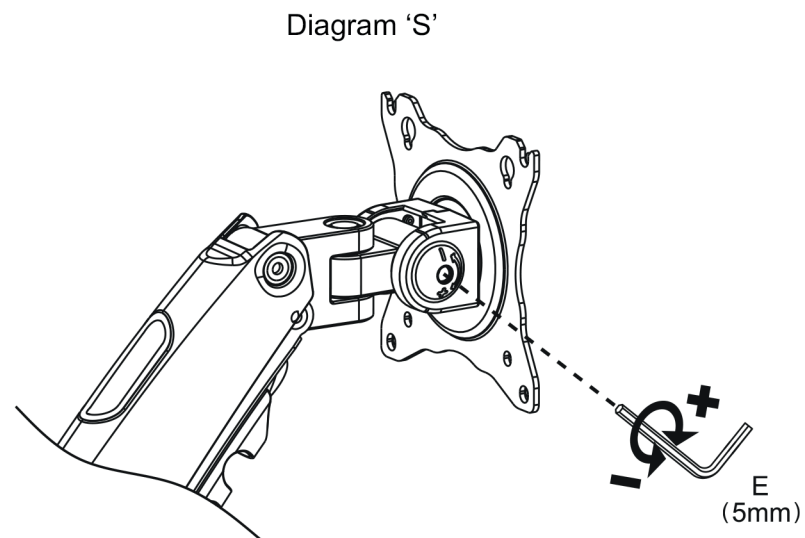

## 7. Rotational Features

1. Your monitor arm allows you to rotate your screen through 360° to view in portrait mode or landscape mode providing the VESA mount on your screen is central.

Please note: Beware of trapping or breaking cables when rotating monitor.

**DO NOT ROTATE MORE THAN 90° IN EACH MOTION.**

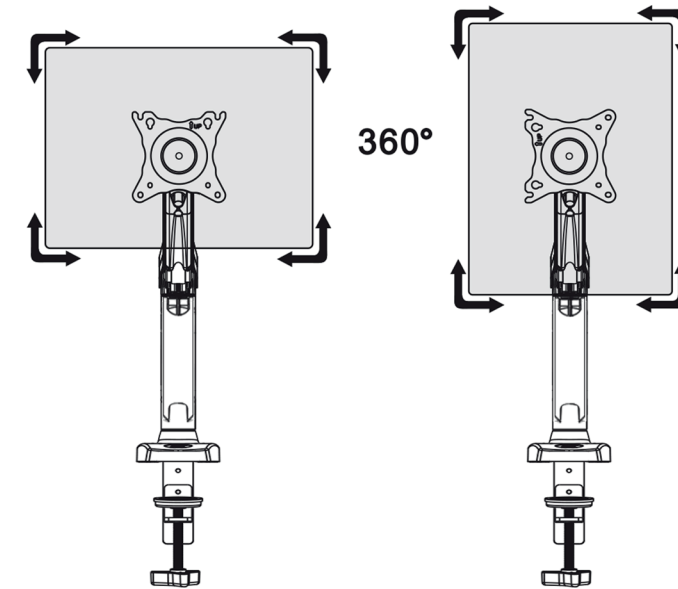

**IMPORTANT:** Please make sure you use this product as displayed in the directions below. Failing to do so could cause injury or damage to your desktop/work-surface.

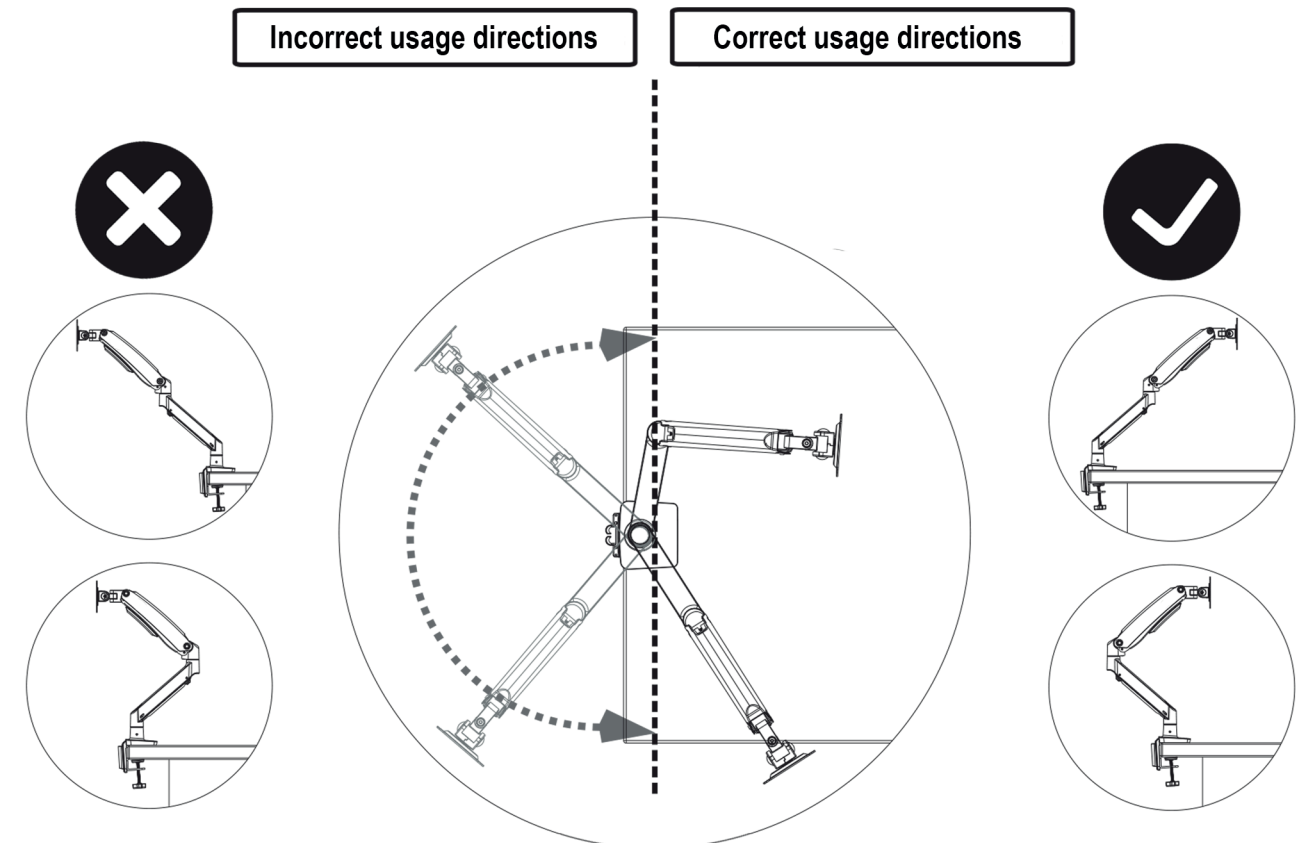

### Troubleshooting:

Don't panic! In case of any issues with compatibility or for any advice on fitting, please contact our team at [help@InvisionTechnology.co.uk](mailto:help@InvisionTechnology.co.uk) and we will help you overcome any problems. All our products carry our Compatibility Promise.

*Your installation is now complete - Sit back & enjoy!*

**To activate your two year warranty please email your name, order number and product ref MX200 to [warranty@InvisionTechnology.co.uk](mailto:warranty@InvisionTechnology.co.uk)**